

STRUCTURAL DESIGN

design issues for structural engineers

Post-Installed Reinforcement

Design Using Adhesive Anchor Systems

By Richard T. Morgan, P.E.

Richard T. Morgan, P.E., is the Manager for Software and Literature in the Technical Marketing Department of Hilti North America. He is responsible for PROFIS Anchor and PROFIS Rebar software. He can be reached at richard.morgan@hilti.com.



Reinforced concrete is a construction method that relies on widely understood and historically validated concepts. Traditionally, reinforcing bars are placed in formwork prior to concrete placement. However, many applications require reinforcement to be added to existing structures by means of reinforcing bars grouted into drilled holes, usually with injectable adhesives. This article provides an overview of how reinforcing bars can be designed in accordance with the development and splice requirements of the American Concrete Institute ACI 318, *Building Code Requirements for Structural Concrete*, using a post-installed adhesive anchor system. Specific reference to the 2012 *International Building Code* (2012 IBC) and ACI 318-11 will be made because the first International Code Council-Evaluation Service (ICC-ES) Evaluation Service Reports (ESRs) containing provisions for designing post-installed reinforcing bars as “reinforcement” are recognized within the 2012 IBC provisions.

Post-installed reinforcing bars, for the purposes of this article, to refer to reinforcing bars installed into hardened concrete using a qualified adhesive anchor system. The primary focus will be to discuss post-installed reinforcing bar design using the development length provisions within ACI 318-11. Alternative design methods for post-installed reinforcement based on anchor theory and shear-friction will also be mentioned.

Anchor Design versus Reinforcement Design

Before discussing the new provisions to design post-installed reinforcing bars for development, it is a good idea to review the current provisions for post-installed anchor design. Post-installed adhesive anchor systems are commonly designed with the Appendix D, *Anchoring to Concrete*, provisions of the ACI 318 code. Anchor elements used with adhesive anchor systems include threaded rod, internally threaded inserts, proprietary anchor elements and reinforcing bars. ACI 318-11 Appendix D contains provisions for calculating design strengths corresponding to anchor failure modes. Bond strength provisions are given in Part D.5.5, *Bond strength of adhesive anchor in tension*. The key concept when using Appendix D to design with reinforcing bars is that the bars act as “anchors” (Figure 1). Essentially, when using Appendix D provisions, the bars are designed in the same manner as anchor bolts. This concept assumes the “anchorage” is subject to three possible failure modes in tension: steel failure, concrete breakout and bond failure; and three possible failure modes in shear: steel failure,

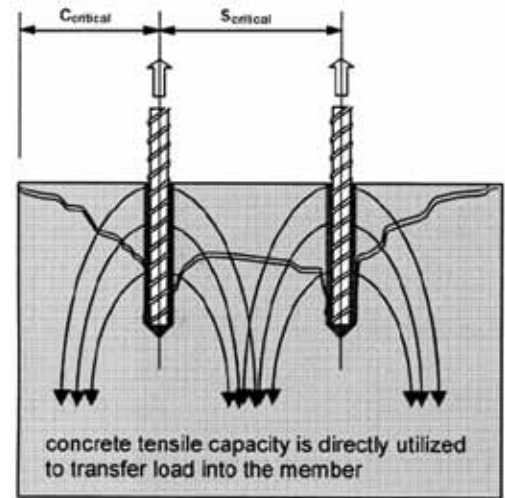

Figure 1. Reinforcing dowels designed using anchor theory.

concrete breakout and concrete pryout. The bars can be treated as a group, such that the effects of spacing and edge distance relative to a specific embedment and characteristic bond strength are considered. Consideration is also given to splitting via the modification factors $\Psi_{cp,N}$ and $\Psi_{cp,Na}$; however, calculation of these parameters is concerned with the increased edge distance required to preclude splitting failure rather than the embedment required to develop the bar to preclude splitting failure.

The predictive expressions for concrete breakout, pryout, etc. in Appendix D do not explicitly consider the influence of reinforcement. However, Appendix D does permit consideration of “supplementary reinforcement” or “anchor reinforcement” to enhance the capacity of an anchorage. The term “supplementary reinforcement” in Appendix D refers to reinforcement capable of controlling splitting, or providing an increased calculated concrete breakout capacity. Reinforcement designed for the strength and serviceability of a concrete member should not automatically be assumed to act as supplementary reinforcement for an anchorage. The term “anchor reinforcement” in Appendix D refers to additional reinforcement specifically designed to preclude concrete breakout failure by transferring the loads applied to the anchorage into bars that will be developed. Reference ACI 318-11 D.5.2.9 (tension) and D.6.2.9 (shear) for more information about Appendix D anchor reinforcement provisions.

In contrast to development length provisions, Appendix D anchorage provisions are not predicated solely on design controlled by the steel strength of the anchor element. Rather, Appendix D provisions simply provide the means to calculate various strengths corresponding to possible anchor failure modes. Furthermore, Appendix D provisions consider “steel strength” to be defined by the specified ultimate tensile strength (f_{uta})

of the steel element. This assumption differs from what is assumed when designing a reinforced concrete member (RCM), in which steel reinforcing bars are designed to yield.

RCM design assumes the reinforcing bars will provide the necessary strength, serviceability and ductility via yielding. RCM design further assumes the reinforcing bars will yield if they are installed at a deep enough embedment to preclude either a splitting failure (small cover) or a pullout failure (large cover). Bars installed at an embedment to obtain yielding are assumed to be “developed”, and the embedment required to “develop” the bar is referred to as the “development length” (Figure 2). All of this is well understood by Structural Engineers. The reason it is noted here is to draw a distinction between reinforcing bars designed with the provisions of Appendix D, and reinforcing bars designed specifically for development. Therefore, unlike Appendix D, design of reinforcing bars for development assumes (a) the bars reach their specified minimum yield strength (f_y), (b) the bar design is controlled by the yield strength instead of the ultimate bar strength and (c) the embedment required to yield the bar will be deep enough to preclude splitting or pullout.

Post-Installed Reinforcing Bar Testing and Assessment

The ICC-ES *Acceptance Criteria for Post-Installed Adhesive Anchors in Concrete Elements* (AC308), establishes requirements for post-installed adhesive anchor systems to be recognized for compliance with the *International Building Code* (IBC). Anchor systems that satisfy these requirements receive an (ICC-ES) Evaluation Service Report. The ESR will note the IBC versions for which recognition has been obtained, describe the materials and components that comprise the anchor system, note design, application and installation parameters, provide tables with design data, and provide Manufacturer’s Printed Installation Instructions (MPII). Additional information is given in a specific ESR. The ESR references the IBC, which in turn references the ACI 318 code. For example, an adhesive anchor system having an ESR that references compliance with the 2012 IBC can be used to design an anchorage per the provisions of ACI 318-11 Appendix D.

AC308 (approved June 2013 for compliance with January 2014 and January 2015) now also addresses the assessment and design of post-installed reinforcing bars for use with the provisions of ACI 318-11 Chapter 12, *Development and Splices of Reinforcement*, and Chapter 21, *Earthquake-Resistant Structures*.

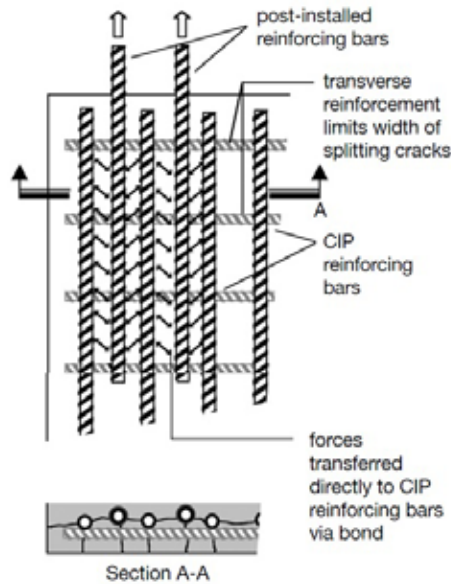

Figure 2. Post-installed reinforcement designed as a lap splice.

The AC308 post-installed reinforcing bar qualification test program includes consideration of the following:

Service Condition Tests

- bond resistance of the post-installed adhesive system
- bond/splitting behavior of the post-installed adhesive system at deep embedment

Reliability Tests

- sensitivity to hole cleaning
- sensitivity to freeze/thaw conditions
- sensitivity to sustained load at elevated temperature
- decreased installation temperature
- sensitivity to installation direction

Installation Procedure Verification

- installation at deep embedment
- injection verification

Durability

- chemical and corrosion resistance

Special Conditions

- seismic qualification

Some of these tests are mandatory and some are optional. Reference Section 2.0, *USES*, and Section 5.0, *CONDITIONS OF USE*, in the ESR for information about the parameters for which the adhesive system has been tested. Reference AC308 for specific details on all test parameters. The intent of the test program is to demonstrate equivalence with cast-in place bars, which will permit a reinforcing bar post-installed using an adhesive system to be designed in accordance with the development and splice requirements of ACI 318. Adhesive systems that successfully complete this test program will receive recognition by way of an ESR, which then permits the adhesive to be used with reinforcing bars

designed as “reinforcement” per the provisions of ACI 318 Chapters 12 and 21. ESRs referencing 2012 IBC compliance will be the first such reports to recognize this type of design. Therefore, post-installed reinforcing bars can now be designed as either an “anchor” using the provisions of ACI 318-11 Appendix D, or as “reinforcement” using the provisions of ACI 318-11 Chapters 12 or 21. This means that post-installed reinforcing bars can now be designed for a development length calculated using the provisions of either Chapter 12 or Chapter 21.

Successfully completing the AC308 test program for post-installed reinforcing bars permits the bars to be designed for development in tension (l_d), or development in compression (l_{dc}), in the same manner as a cast-in-place bar. AC308 qualification testing for design per the provisions of Appendix D limits the embedment depth of an anchor element to a maximum of $20(d_{anchor})$. AC308 qualification testing for design per the provisions of ACI 318 Chapter 12 or Chapter 21 limits the embedment depth of a post-installed reinforcing bar to a maximum of $60(d_{anchor})$. Therefore, a key parameter for using adhesive systems with the provisions of Chapter 12 or Chapter 21 is to qualify for installation at deep embedment via the test program defined in AC308 Table 3.8. Satisfying this parameter is one way in which the system demonstrates equivalence with cast-in-place reinforcing bars. Note that post-installed reinforcing bar installation is only relevant to straight bars. The structural analysis required to determine the area of reinforcement (A_s) for post-installed reinforcing bars will be per the relevant provisions of the ACI 318 code.

Designing Post-Installed Reinforcing Bars as Reinforcement

Consider an application for a slab extension in which reinforcing bars post-installed with an adhesive will be used. The post-installed bars will need to be spliced to the reinforcement in the existing member (Figure 3, page 16). Assume the slab is subjected to non-seismic tension loads, and design is per the 2012 IBC. Assume the adhesive has been qualified per the test program defined in AC308 Table 3.8. Reinforced concrete design principles would be used to determine a post-installed bar size and grade. The development length for the post-installed bars would be calculated using ACI 318-11 Eq. (12-1). Lap splices would follow Section 12.15, *Splices of deformed bars and deformed wires in tension*. If the existing

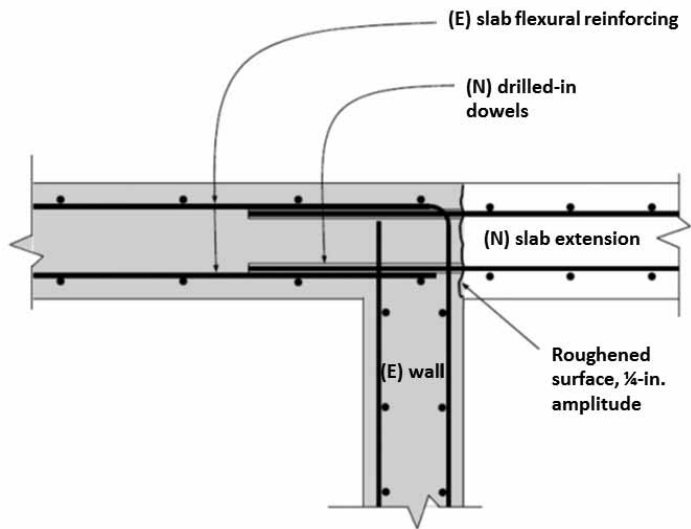

Figure 3. New slab extension to an existing slab.

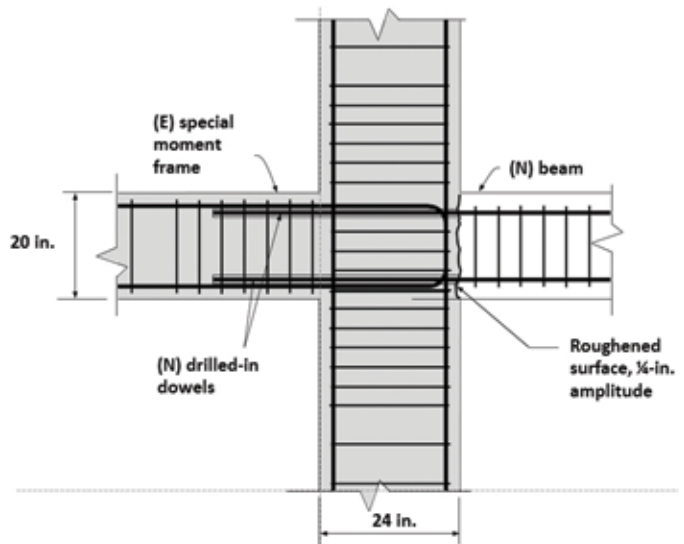

Figure 4. Extension of an existing special moment frame.

reinforcement bar size was the same as the post-installed bar size, the lap splice length would be calculated using the provisions of Section 12.15.1. If the criteria of 12.15.2 could be satisfied, a Class A splice could be used; otherwise, a Class B splice would be used. Likewise, if the existing reinforcement bar size was different from the post-installed bar size, the lap splice length would be calculated using the provisions of Section 12.15.3. Once a bar size and splice length has been determined, the detailing would be in accordance with ACI 318-11 Section 7.6, *Spacing limits for reinforcement*, and Section 7.7, *Concrete protection for reinforcement*; subject to any additional conditions per the required code parameters and the product-specific ESR. The MPEI would be followed when installing the new bars.

Now, consider reinforcing bars post-installed to permit extension of an existing special moment frame (Figure 4). Reinforced concrete design principles would be used to determine a post-installed bar size and grade. Assuming the adhesive has been qualified per the test program defined in AC308 Table 3.8, the development length for the post-installed bars would be calculated using the provisions of ACI 318-11 Section 21.7.5, *Development length of bars in tension*. Specifically, Eq. (21-6) in Section 21.7.5.1 and the provisions of Sections 21.7.5.2 and 21.7.5.3 would be used to calculate the development length. Once a bar size and development length has been determined, detailing would be in accordance with ACI 318-11 Section 7.6 and Section 7.7, subject to any additional conditions per the required code parameters and the product-specific ESR. The MPEI would be followed when installing the new bars.

Adhesive systems qualified per AC308 permit design and detailing of post-installed reinforcing bars with the same criteria as that for

cast-in-place bars. In order to complete the post-installed reinforcing bar design, the installation requirements given in the MPEI must be followed. Determining the method for drilling the hole in the existing concrete, making sure that the hole is drilled to the required depth and properly cleaned, installing the adhesive in a manner that eliminates voids and permits proper bar insertion, and allowing the adhesive to cure without any disturbance are parameters that must be considered when post-installing the reinforcing bars.

Additional installation parameters are given in the ACI 318 building code and in the product-specific ESR. The ACI 318-11 code addresses adhesive anchor installation in Appendix D via D.9, *Installation and inspection of anchors*. Adhesive anchor ESRs address installation requirements in Section 4.0, *DESIGN AND INSTALLATION*, and Section 5.0, *CONDITIONS OF USE*. The MPEI, ACI 318-11 D.9 provisions, and product-specific ESR provisions must be followed when designing and installing post-installed reinforcing bars with an adhesive anchor system.

Alternative Design Methods

Design of post-installed reinforcing bars is an ongoing area of research and testing. Charney et al have proposed an approach that utilizes anchor theory to calculate a post-installed reinforcing bar development length. This approach is premised on calculating a development length that takes into consideration concrete breakout failure and bond failure when splitting failure no longer controls. The calculations utilize the concrete breakout and bond strength equations of ACI 318-11 Appendix D.

Palieraki et al have proposed an approach that does not require bar development for

applications being designed for shear transfer. The resulting bar embedment could be less than that required per ACI 318-11 Section 11.6.4, *Shear-friction design method*.

Developing a code-approved approach to design anchor bolts for development is another area where research would be beneficial.

Summary

The focus of this article was post-installed reinforcing bar design using the development and splice requirements of ACI 318-11. Only adhesive systems that have been qualified per the post-installed reinforcing bar provisions of the ICC-ES Acceptance Criteria AC308 are relevant for this design. Recognition for this design will be given in a product-specific ICC-ES Evaluation Service Report. The importance of understanding the requirements and limitations given in the ESR, following the Manufacturer's Printed Installation Instructions, and following all code-related provisions for design and installation, are emphasized. ■

References

- Charney, A., Pal, K., and Silva, J. (2013). *Recommended Procedures for Development and Splicing of Post-Installed Bonded Reinforcing Bars in Concrete Structures*, ACI Structural Journal, Vol. 110, No. 3, pp. 437-447.
- Palieraki, V., Vintzileou, E., Trezos, K. (2014). *Shear Transfer Along Interfaces: Constitutive Laws*, Proceedings of the 2nd European Conference on Earthquake Engineering and Seismology, Istanbul, Turkey (electronic source).